

HARRINGTON
HOISTS AND CRANES



ELECTRIC
WIRE ROPE
HOISTS

RH Electric Wire Rope Hoists

Harrington RH wire rope hoists are designed and built for today's heavy-duty wire rope hoist applications including fabricating, die handling, paper mill and production line work. State-of-the-art design features and construction make the RH extremely durable, highly reliable and very low maintenance for years of trouble free service.

The RH includes features that are expensive options on competitive hoists to include standard electromechanical load limiting device, fan-cooled motors and rubber trolley bumpers. Maintenance and failures associated with disc type brakes are eliminated with our revolutionary pull rotor brake system. The sealed hoist enclosure means airborne grit and contamination will not penetrate the hoist to cause premature failure of electrical components. A truly unique wire rope guide prevents improper rope alignment on the grooved drum.

The RH's design is maintenance friendly. Examples are a hinged electrical panel and external geared limit switches to minimize hoist downtime and expense.

High quality paint
is electrostatically applied for corrosion resistance in harsh environments

Sealed electrical enclosure with IP55 rating *suitable for outdoor service and provides extra protection for indoor applications*

Pull rotor brake
is asbestos free and fan cooled to ensure long life

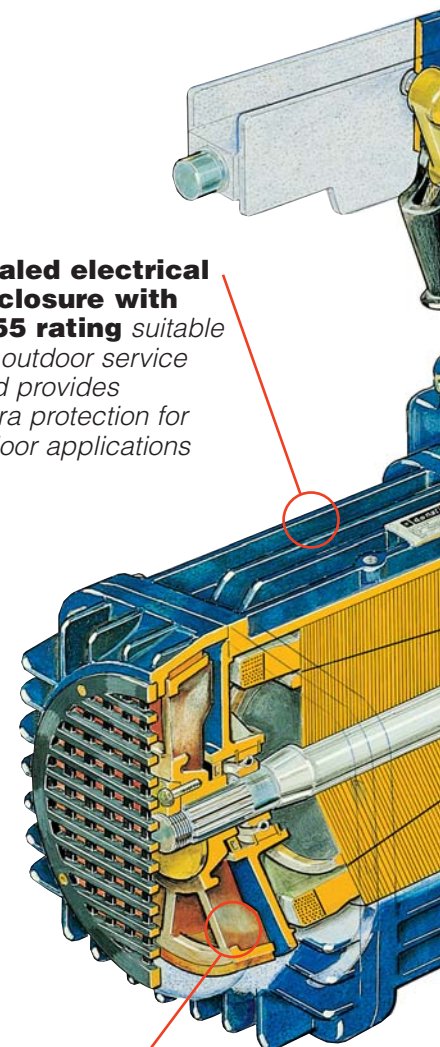

Electro-mechanical load limiter prevents lifting of over capacity loads

External limit switches protect against hook overtravel

Electrical components are mounted on hinged panels for easy servicing

Self-tensioning rope guide keeps the rope securely in its groove on the drum

Low profile minimizes wasted space and reduces headroom

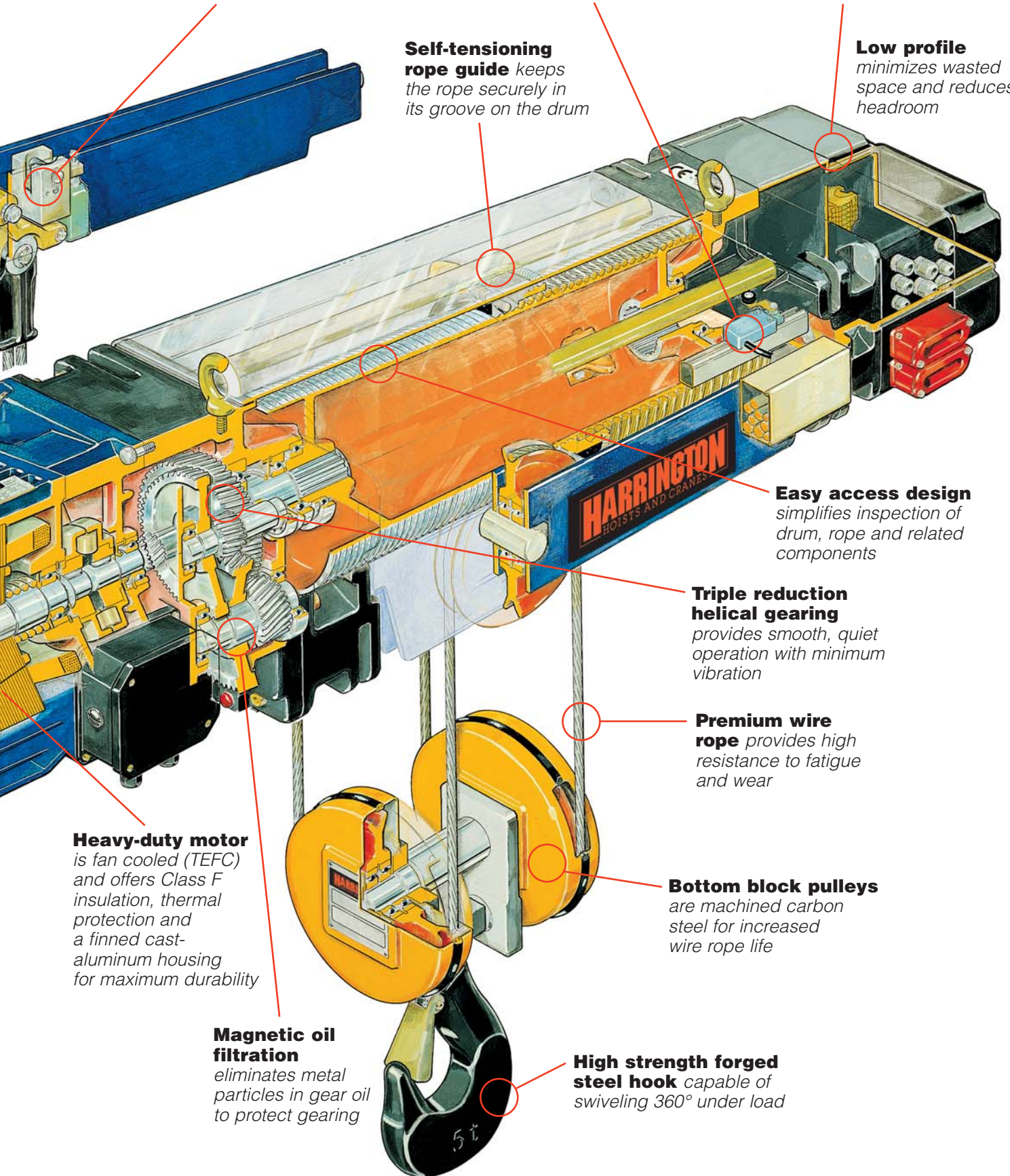

Easy access design simplifies inspection of drum, rope and related components

Triple reduction helical gearing provides smooth, quiet operation with minimum vibration

Premium wire rope provides high resistance to fatigue and wear

Bottom block pulleys are machined carbon steel for increased wire rope life

Heavy-duty motor is fan cooled (TEFC) and offers Class F insulation, thermal protection and a finned cast-aluminum housing for maximum durability

Magnetic oil filtration eliminates metal particles in gear oil to protect gearing

High strength forged steel hook capable of swiveling 360° under load

RH Electric Wire Rope Hoists and Trolleys

Standard Specifications

| | |
|--------------------------------------|--|
| Capacities (Tons): | 2, 3, 5, 7½, 10, 15, 20 |
| Lift Range (feet): | 20' to 105' |
| Lifting Speeds (ft/min): | 16, 24, 32, 48 |
| Dual Lifting Speeds (ft/min): | 16/5, 24/8, 32/10, 48/16 |
| Trolley Travel Speeds (ft/min): | 40, 64, 80 |
| Dual Trolley Travel Speeds (ft/min): | 64/16, 80/20 |
| Supply Voltages: | 230-3-60, 460-3-60 |
| Control Voltage: | 110VAC |
| Reeving: | 4/1 (four-part single reeved) or 2/1 (two-part single reeved) |
| Configurations: | <ul style="list-style-type: none"> • Deck/base mounted or lug suspended hoists • Standard or ultra-low headroom trolley hoists |

Note: Other capacities, speeds, lifts and voltages available — consult factory. Refer to pages 2 and 3 for more detailed standard features.

Many Trolley Benefits from More Standard Features

Electric Trolley Brake

- Provides positive stopping power and ultimate load control during loading and unloading.

Rubber Trolley Bumpers

- Bumpers are standard equipment.
- Bumpers reduce mechanical impact against trolley stops and are required for trolley hoist installation on overhead bridge cranes.

Heavy-Duty Trolley Drive

- Fan-cooled TEFC drive motor provides long, trouble-free service.
- IP55-rated, suitable for outdoor service and adds extra protection for indoor applications.
- Helical gear drives in oil bath provides cool, quiet and smooth operation.
- Magnetic oil filtration removes suspended metal particles to increase gear life.

Dual-Side Trolley Drive

- Two driven wheels offer better traction for improved operator control.
- Driven wheels on opposite sides of the trolley provide smoother operation with less racking and skewing.

Extended Wheelbase Design

- Larger wheelbase than competitive units offers more stable travel.
- Provides better load distribution over the beam to reduce beam loading.

Dual Tread Wheels With Gear Guards

- Flat and tapered tread section is ideal for S or W beams.
- Ensures smooth tracking on wide flange beams common in industry.
- Gear guards protect gear ring and flange, as well as personnel.

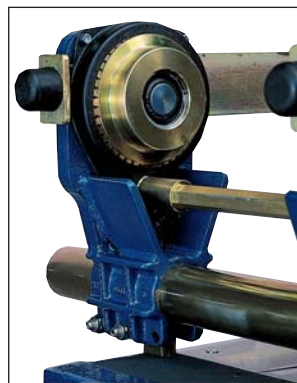

Deck/Base Mounted or Lug Suspended Hoists

For permanent installation or double-girder trolley applications, the Harrington deck/base mounted or lug suspended hoists are ideal for heavy-duty service.

- Modular body construction suitable for all mounting configurations.
- Single-axis or in-line design with motor, gearbox and drum sharing the same axis results in a low-profile, low-headroom hoist.
- For features and standard specifications, refer to pages 2, 3 & 4.
- For detailed specifications and dimensions, refer to Harrington's separate publication entitled "Electric Wire Rope Hoists Technical Manual."

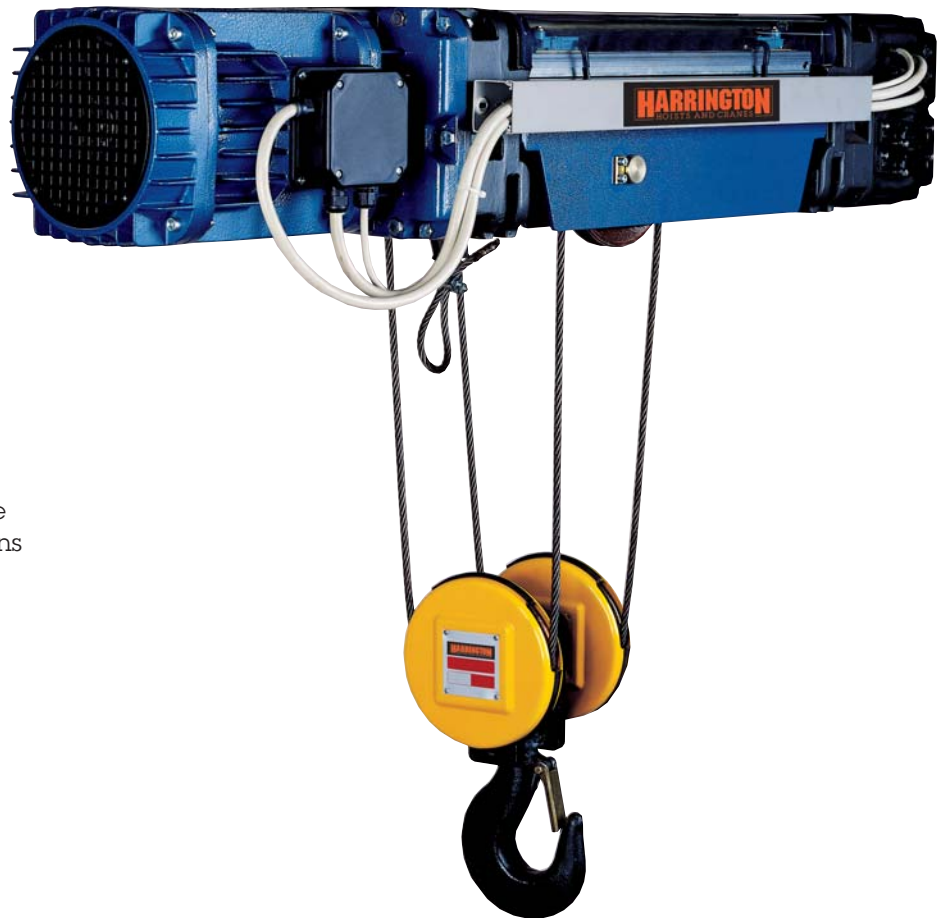

Options

- Universal eye-bolt kit suitable for all mounting configurations
- Pendant
- Pendant cord
- Power supply cord

Standard Headroom Trolley Hoists

For general use on bridge, gantry or jib cranes, as well as monorails, this standard Harrington monorail style trolley hoist combines versatility and performance.

- Available in any combination of single or dual speed models in a variety of speed combinations.
- Hoist oriented parallel to beam.
- For features and standard specifications, refer to pages 2, 3 & 4.
- For detailed specifications and dimensions, refer to Harrington's separate publication entitled "Electric Wire Rope Hoists Technical Manual."

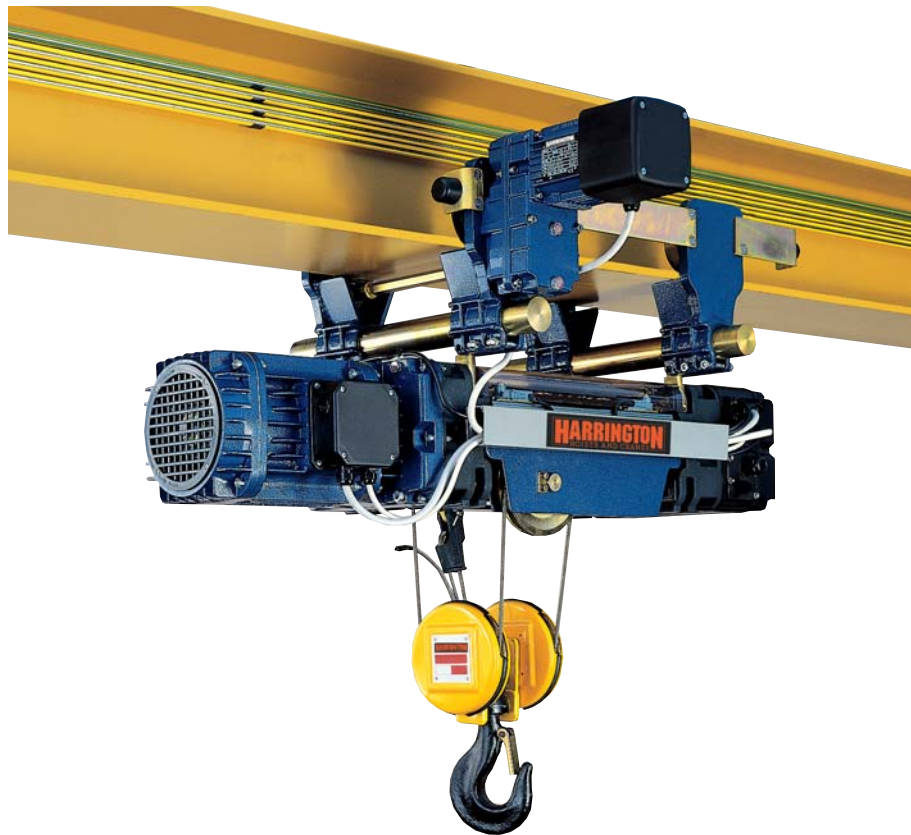

Options

- Pendant
- Pendant cord
- Power supply cord
- Trolley travel limit switch

Ultra-Low Headroom Trolley Hoists

The Harrington Ultra-Low Headroom Trolley Hoist is designed for monorail and crane applications where minimum headroom is essential.

- The hoist body is parallel mounted beside the beam for extremely low headroom.
- A weight is mounted opposite the hoist to balance the unit on the monorail.
- For features and standard specifications, refer to pages 2, 3 & 4.
- For detailed specifications and dimensions, refer to Harrington's separate publication entitled "Electric Wire Rope Hoists Technical Manual."

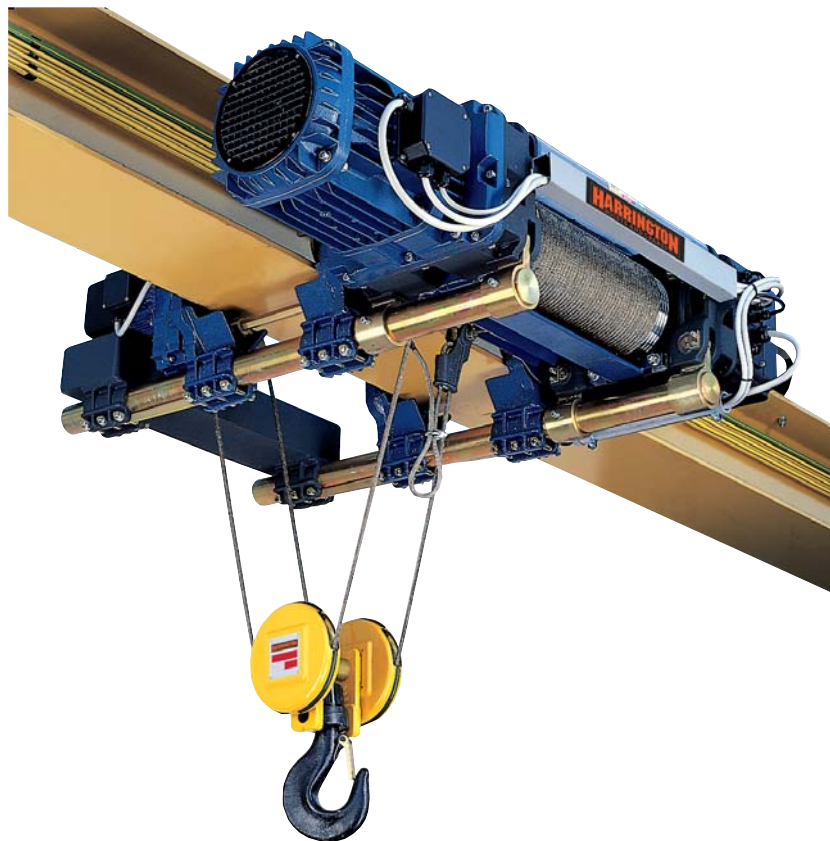

Options

- Pendant
- Pendant cord
- Power supply cord
- Trolley travel limit switch

**CONTACT YOUR NEARBY
HARRINGTON DISTRIBUTOR**

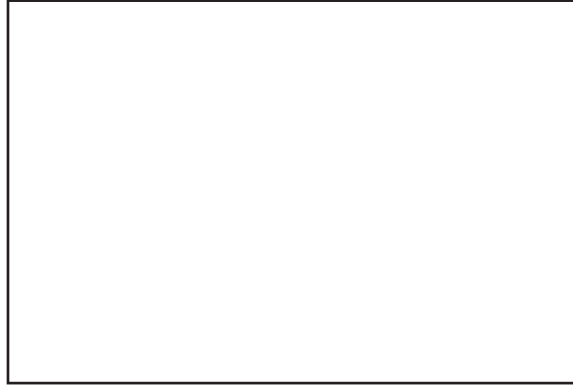

Warranty

All products sold by Harrington Hoists, Inc. are warranted to be free from defects in material and workmanship from date of shipment by Harrington for the following periods:

Manual Hoists & Trolleys - 2 years

Electric Hoists, Air Hoists & Trolleys, Crane Components - 1 year

Spare / Replacement Parts - 1 year

The product must be used in accordance with manufacturer's recommendations and must not have been subject to abuse, lack of maintenance, misuse, negligence, or unauthorized repairs or alterations.

Should any defect in material or workmanship occur during the above time period in any product, as determined by Harrington Hoist's inspection of the product, Harrington Hoists, Inc. agrees, at its discretion, either to replace (not including installation) or repair the part or product free of charge and deliver said item F.O.B. Harrington Hoists, Inc. place of business to customer.

Customer must obtain a Return Goods Authorization as directed by Harrington or Harrington's published repair center prior to shipping product for warranty evaluation. An explanation of the complaint must accompany the product. Product must be returned freight prepaid. Upon repair, the product will be covered for the remainder of the original warranty period. If it is determined there is no defect, or that the defect resulted from causes not within the scope of Harrington's warranty, the customer will be responsible for the costs of returning the product.

Harrington Hoists, Inc. disclaims any and all other warranties of any kind expressed or implied as to the product's merchantability or fitness for a particular application. Harrington will not be liable for death, injury to persons or property, or for incidental, contingent, special or consequential damages, loss or expense arising in connection with the use or inability whatever, regardless of whether damage, loss, or expense results from any act or failure to act by Harrington, whether negligent or willful, or from any other reason.



Harrington Hoists, Inc.,
401 West End Ave., Manheim, PA 17545
717.665.2000 / 800.233.3010
Fax: 717.665.2861

Western Division/Factory Warehouse,
2341 Pomona Rincon Rd., No. 103, Corona, CA 92880-6973
909.279.7100 / 800.317.7111
Fax: 909.279.7500

www.harringtonhoists.com